

REED SWITCHES

REED SENSORS

REED RELAYS



MEDER electronic group

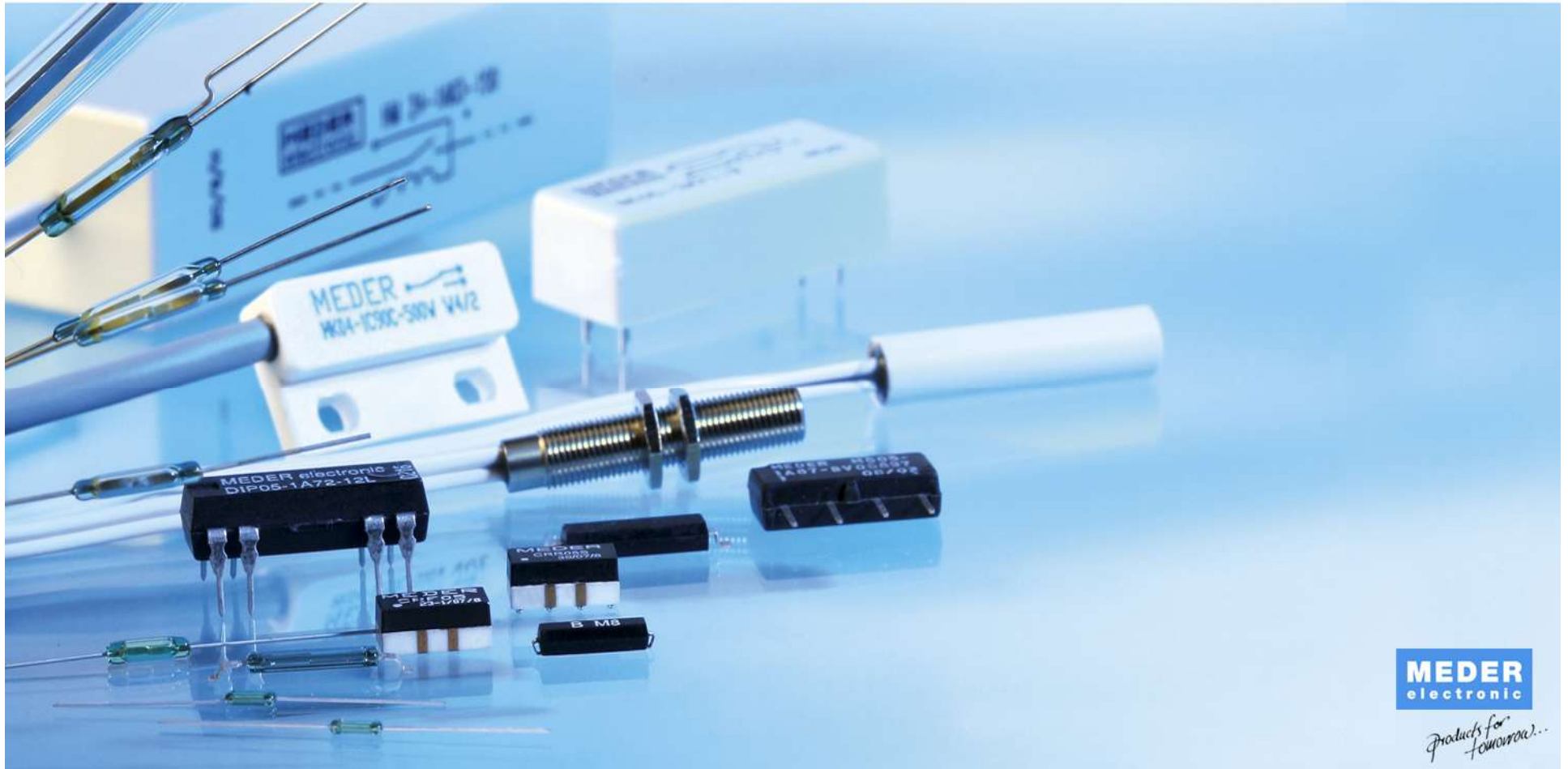

MEDER
electronic

*Products for
Tomorrow...*

Relays for RF applications II

Copyright: John Beigel,
MEDER electronic group
<http://www.meder.com>

04/06/2010

REED SWITCHES

REED SENSORS

REED RELAYS



Table of contents

- Ways to improve RF performance
- Shortening the signal paths
- Ways to improve insertion loss
- Ways to improve isolation
- Grounding the start wire
- MEDER Relays for RF

REED SWITCHES

REED SENSORS

REED RELAYS



Ways to improve RF performance

- Controlling the impedance path through the relay maintaining 50 ohms
- Shortening the signal path length by making a smaller relay (length wise)

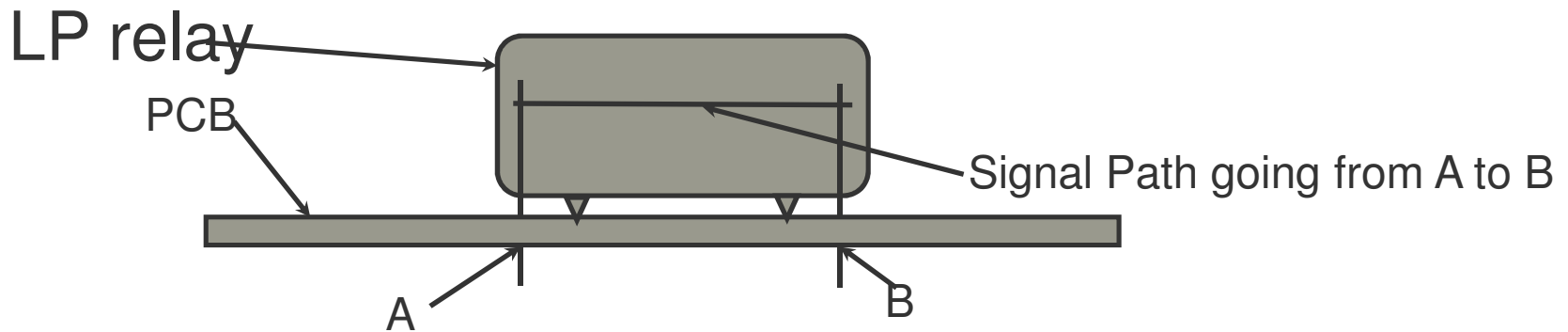

REED SWITCHES

REED SENSORS

REED RELAYS

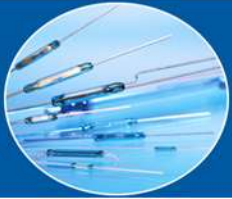

Shortening the signal paths

SIL relay

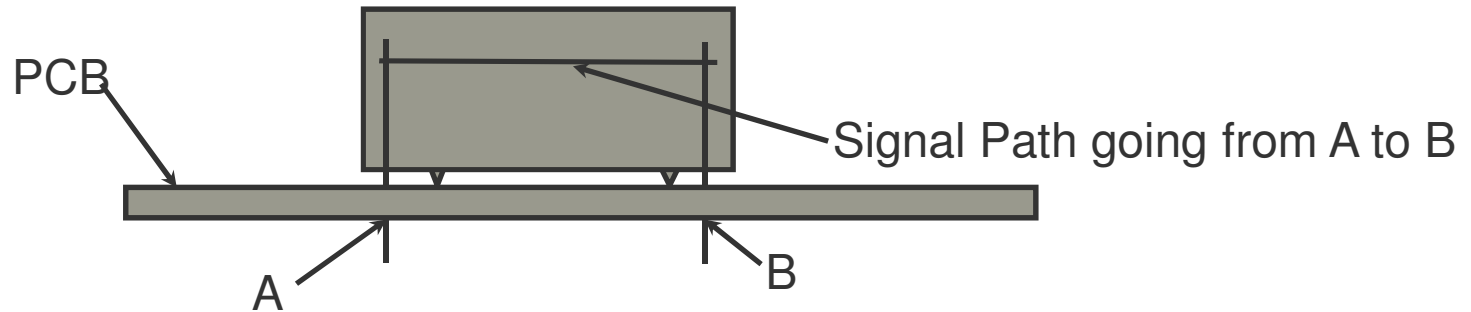

MS relay

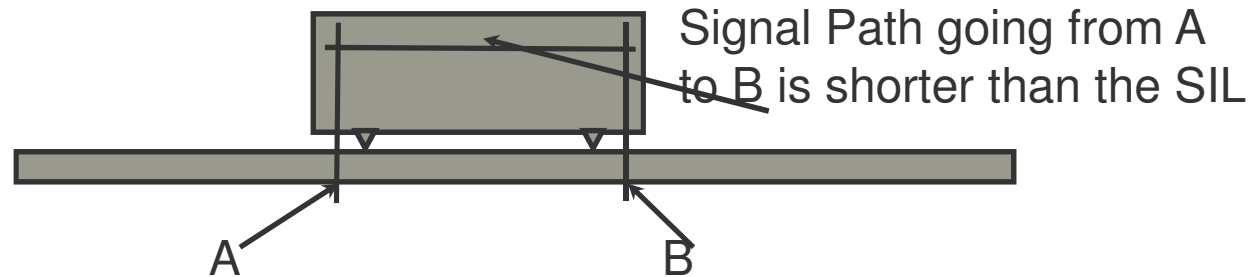

REED SWITCHES

REED SENSORS

REED RELAYS



Shortening the signal paths

CRF relay

Signal Path going from A to B showing a dramatic reduction in signal path eliminating the double length of going through the PCB

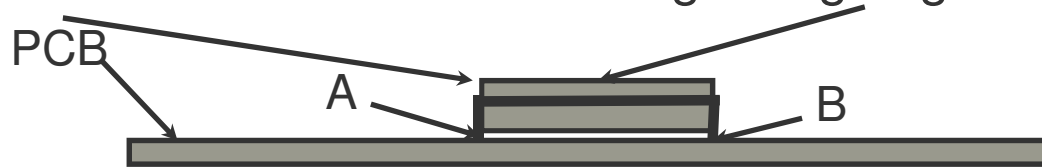

SRF relay

Signal Path going from A to B eliminating the path length down the side of the relay

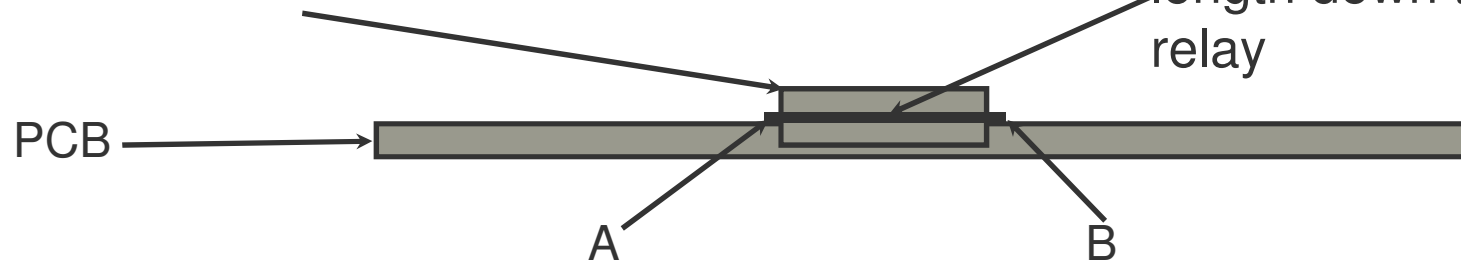

REED SWITCHES

REED SENSORS

REED RELAYS

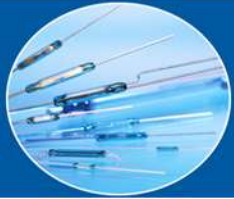

Shortening the signal paths

- An example of how the RM 6 pole eliminates signal path length by avoiding going out the relay and down the side of the package to the PCB and then going over the PCB to a new relay, then having to go up and into the second relay

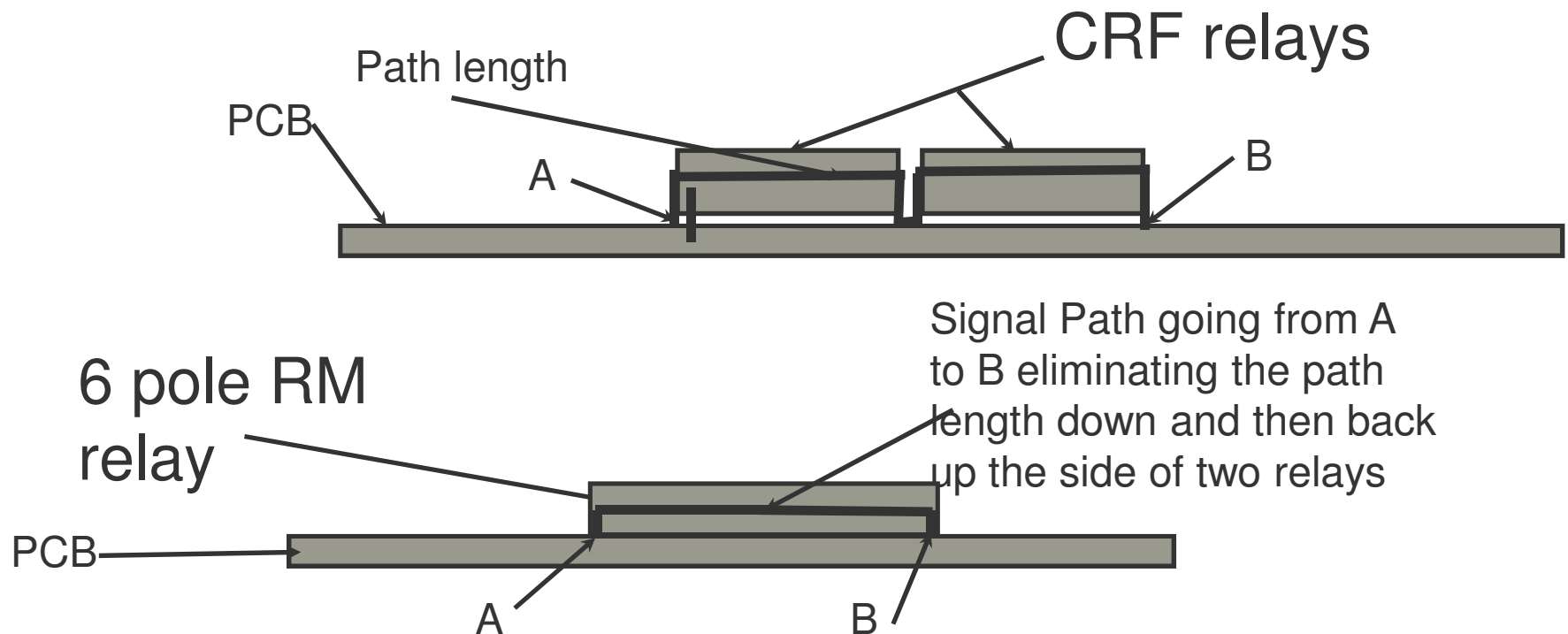

REED SWITCHES

REED SENSORS

REED RELAYS



Ways to improve RF performance

- Minimize geometric changes to the signal path.

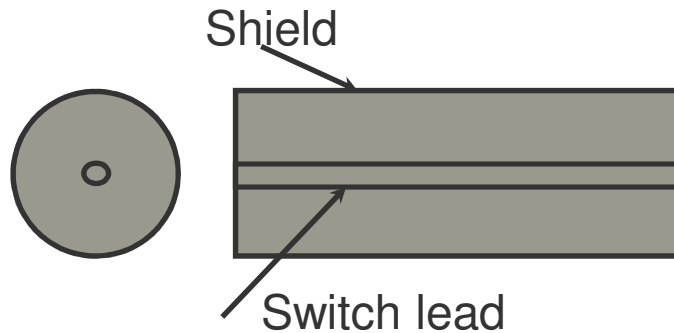

- Minimize the overmolding or eliminate it and or only have a short stub of the switch available

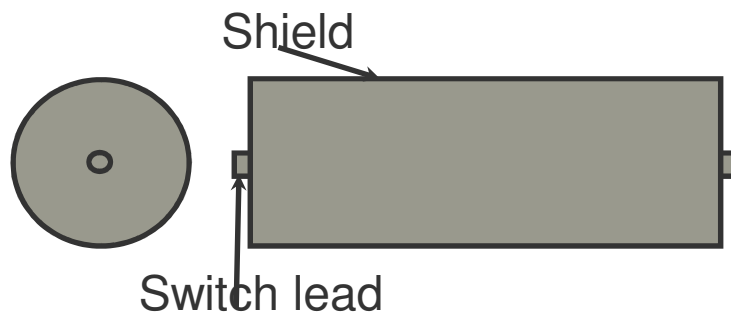

REED SWITCHES

REED SENSORS

REED RELAYS

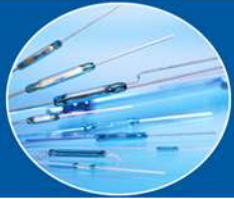

Ways to improve RF performance

- Reduce or eliminate any sharp corners in the signal path.
- Eliminate any unnecessary metal stubs attached to the signal path.
- Design a packaged relay Matrix, for example our RM-6-pole

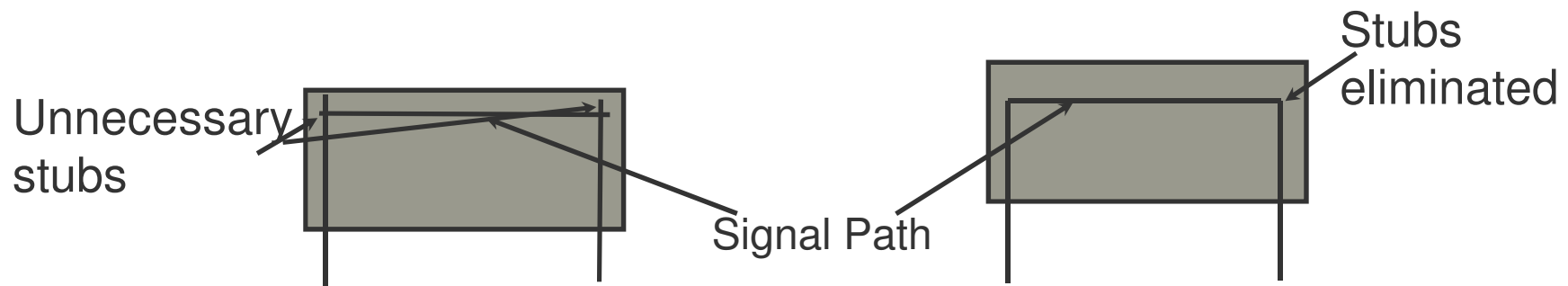

REED SWITCHES

REED SENSORS

REED RELAYS



Ways to improve insertion loss

- Match the impedance in and out of the relay with the PCB (customer)
- Surface mount is much better than thru hole
- Place the surface mount relay axially into a PCB cutout

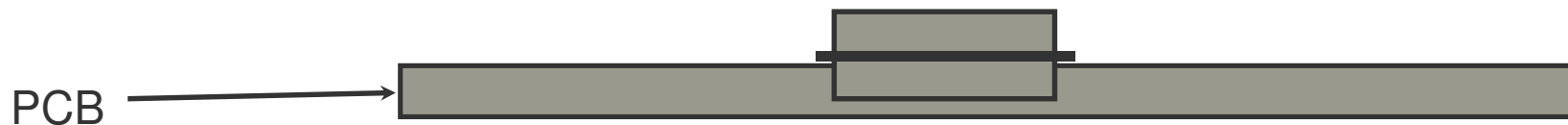



Ways to improve isolation

- Using higher AT switches works to a limit, where the sacrifice of increased coil power becomes too big a drain.
- Using a 'T' or 1/2 'T' switching arrangement will increase isolation.
- The 'T' switch basically has two relays in series (both in the open state) and at their junction a third relay is connected to ground (this relay is normally closed).
- Any signal leaking thru the first relay in series will be theoretically shunted to ground.
- The second relay in series will further isolate any signal that is left at the junction of the three relays

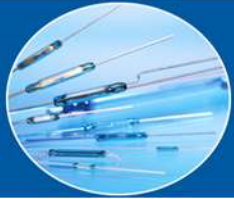

Ways to improve isolation

1/2 T Switching

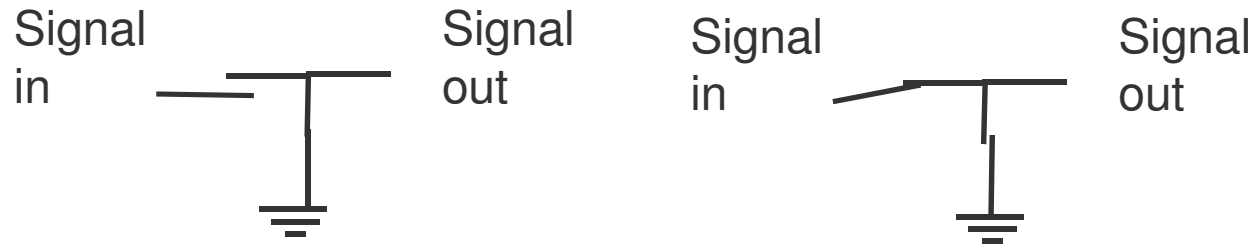

Full 'T' Switching

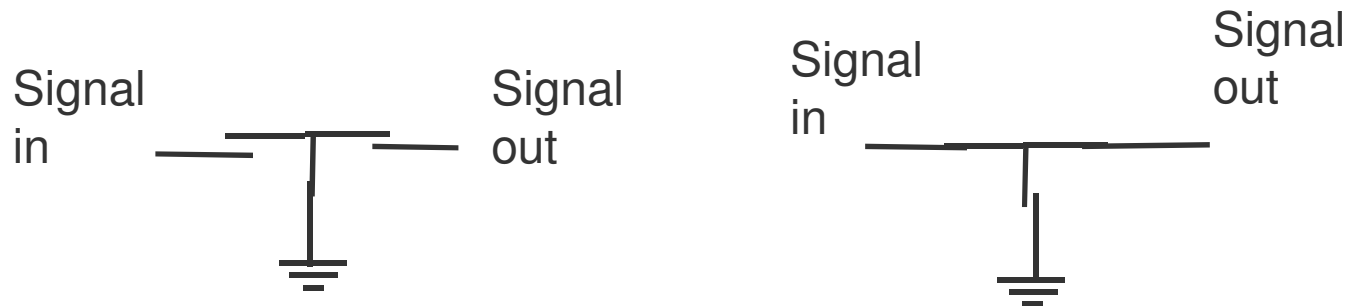

- As can be seen the 1/2T and T switch will improve the isolation, but what also can be seen in transmission mode, the path length has increased and we have added stubs
- So the insertion loss and frequency response will suffer.

REED SWITCHES

REED SENSORS

REED RELAYS



Grounding the start wire

- The start wire and its subsequent turns covering the first wound layer on the coil form essentially make up the shield.
- This first layer looks like a cylinder surrounding the switch
- Therefore grounding the start wire will act very efficiently as the signal ground
- So the cylinder coupled with the reed switch make up a coaxial cable giving good RF performance
- This allows us to use the LP, SIL and MS series as RF relays

REED SWITCHES

REED SENSORS

REED RELAYS

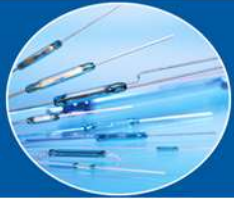

MEDER Relays for RF applications

- LP Series - DC to 500 MHz

LP05-1C90 Insertion Loss with start-wire grounded

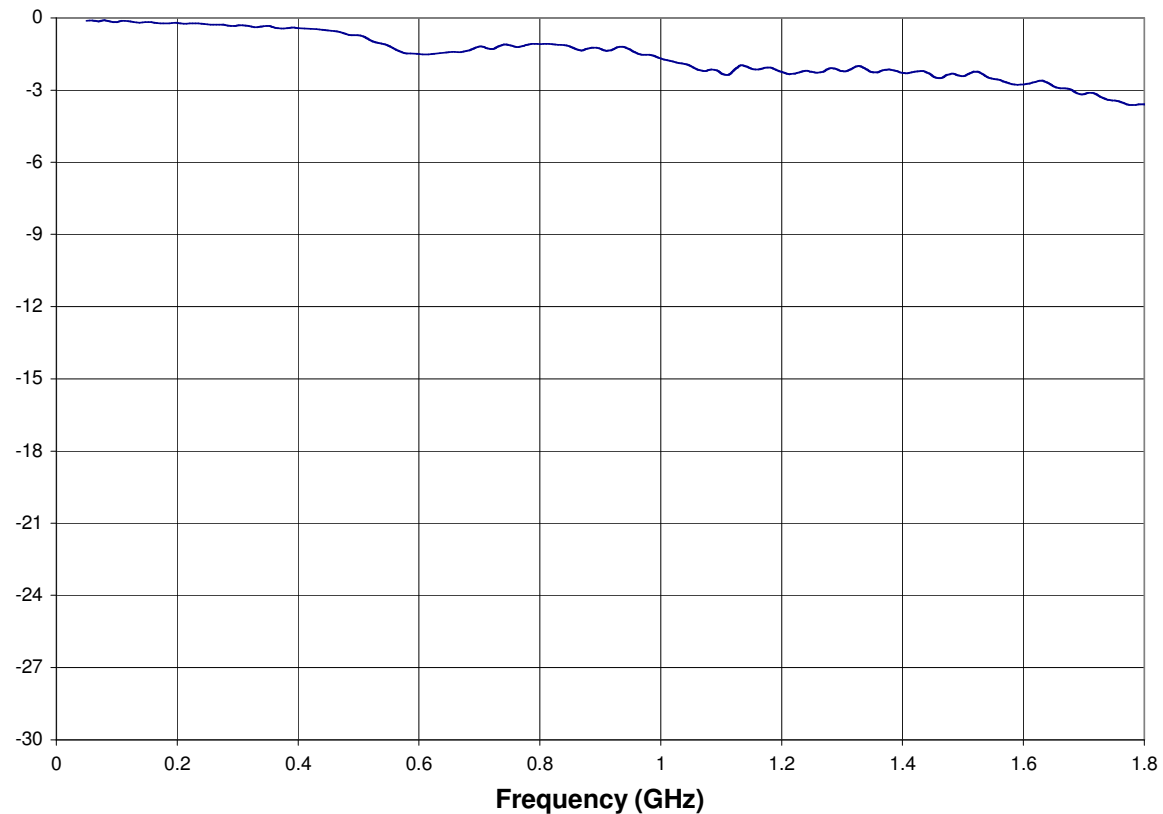

REED SWITCHES

REED SENSORS

REED RELAYS

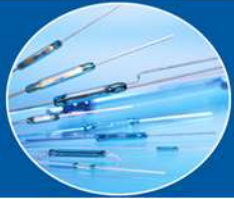

MEDER Relays for RF applications

- SIL Series - DC to 800 GHz

SIL05-1A72 Insertion Loss with start-wire grounded

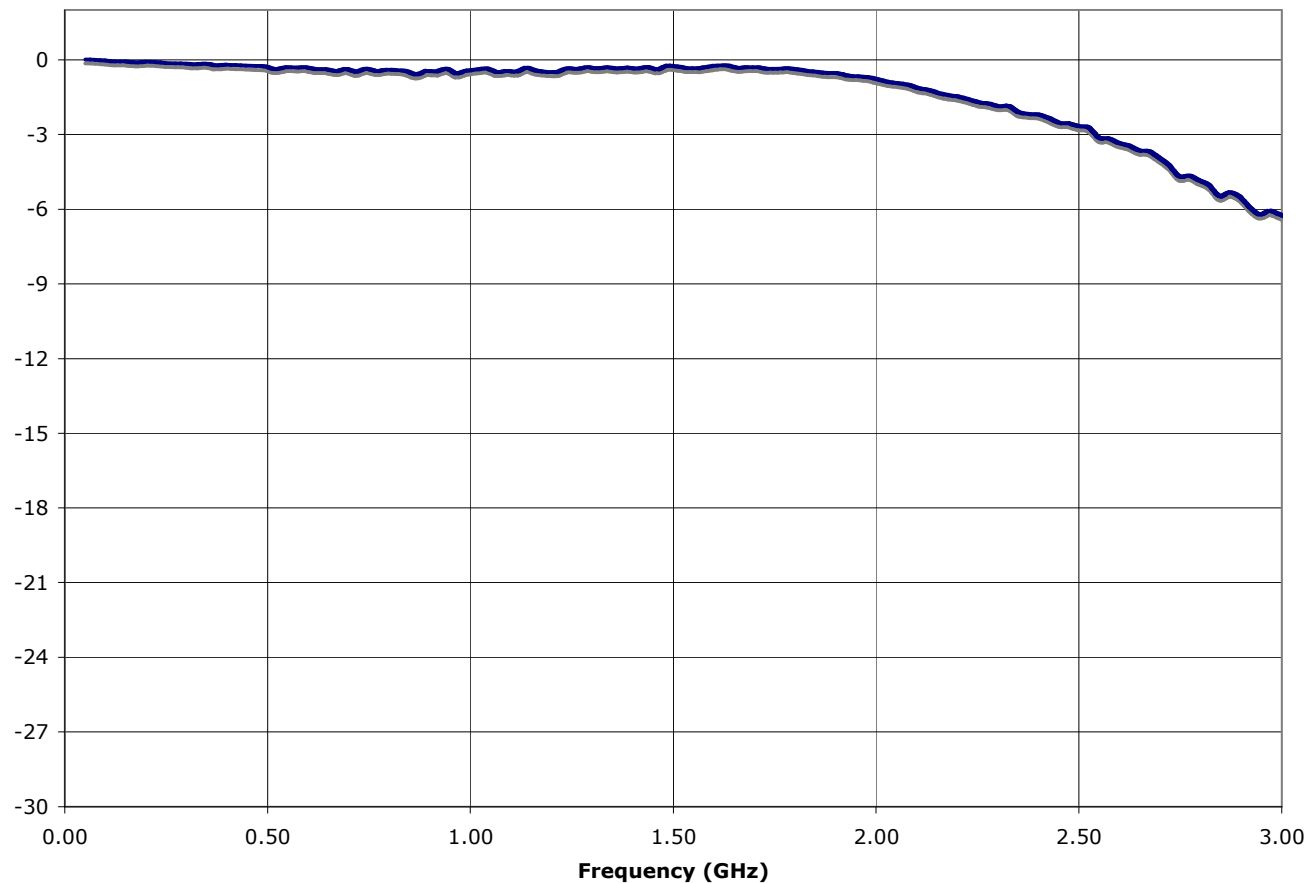

REED SWITCHES

REED SENSORS

REED RELAYS

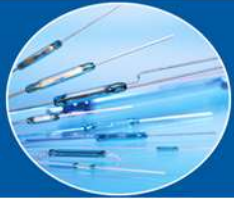

MEDER Relays for RF applications

- MS Series - DC to 1.5 GHz

MS05-1A87 Insertion Loss with start-wire grounded

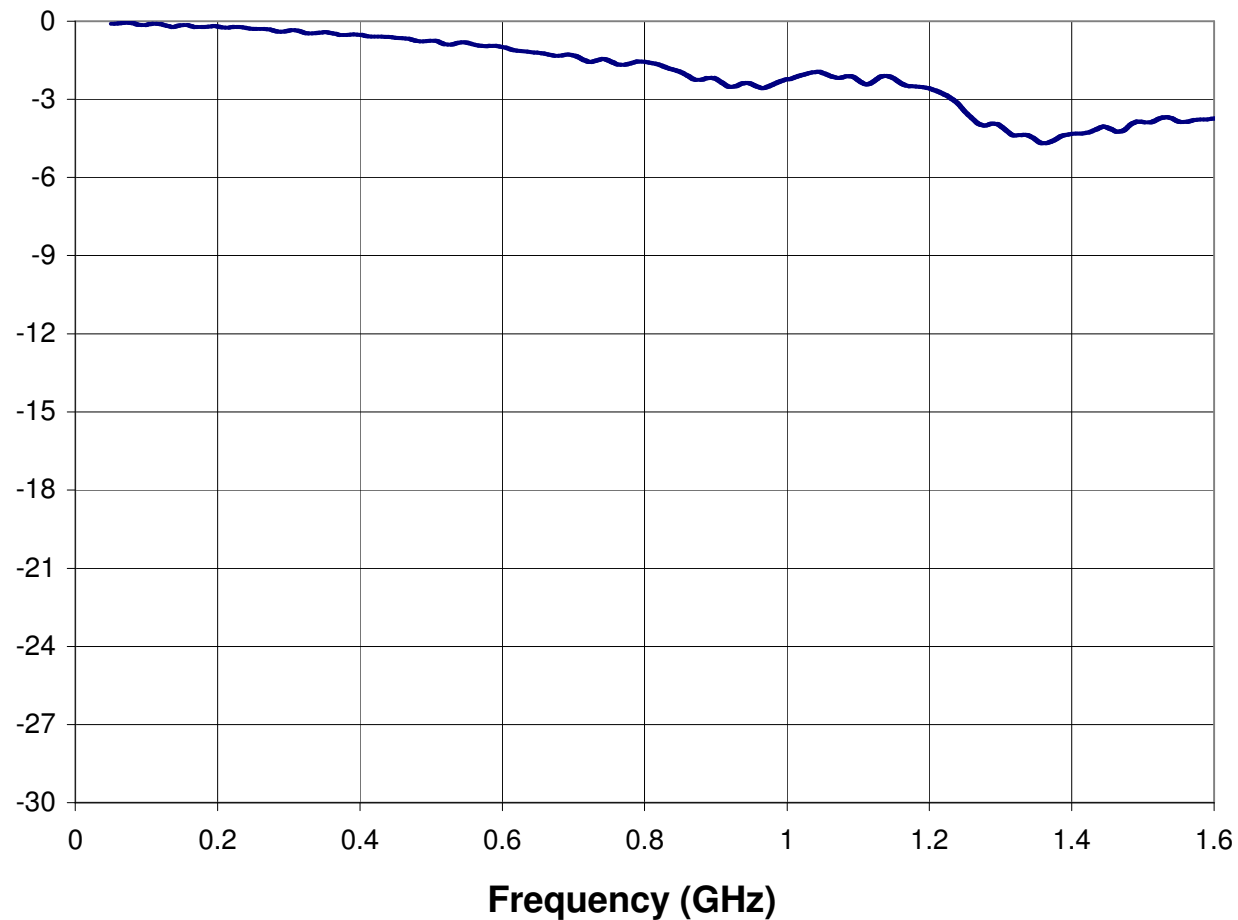

Copyright: John Beigel,
MEDER electronic group
<http://www.meder.com>

REED SWITCHES

REED SENSORS

REED RELAYS



MEDER Relays for RF applications

- CR Series - DC to 7 GHz

CRF Insertion Loss

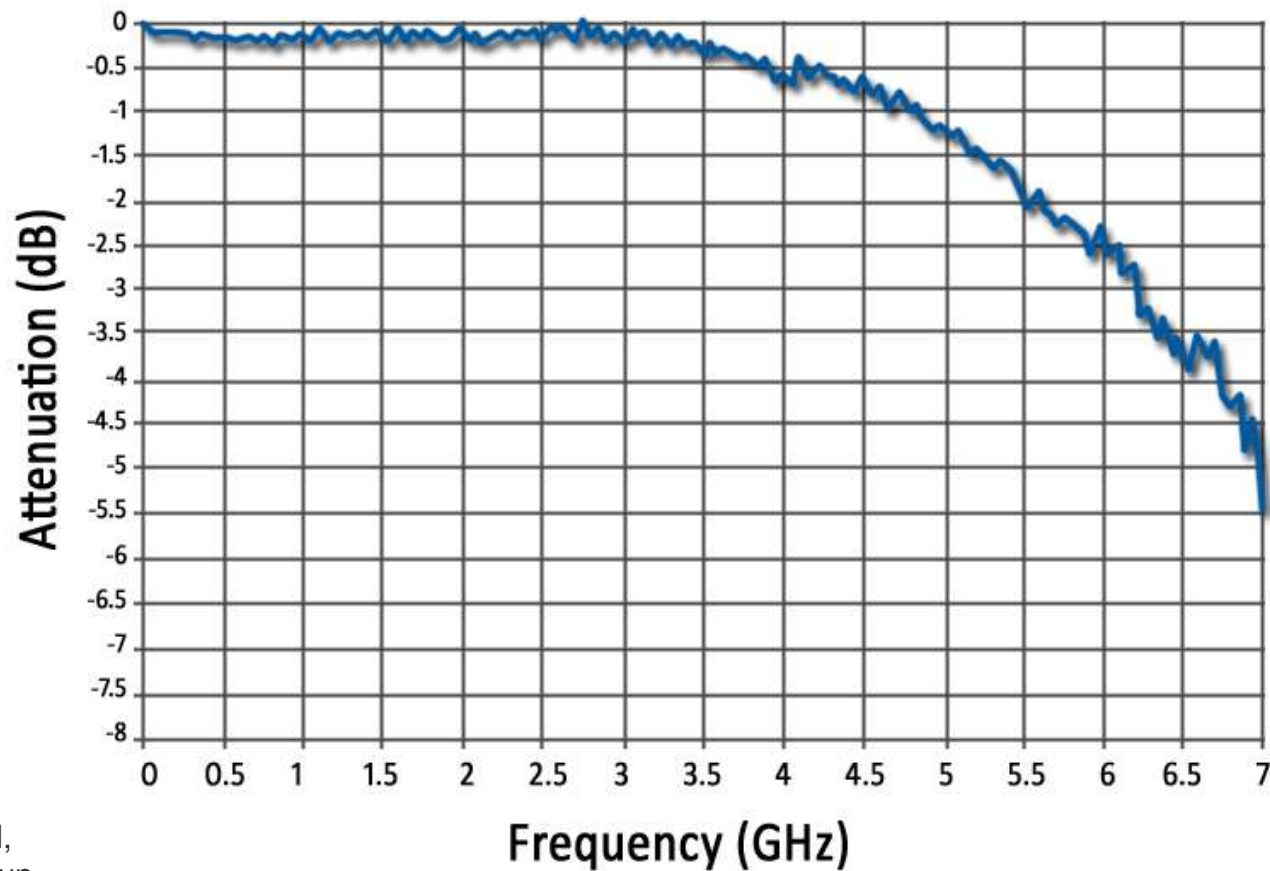

Copyright: John Beigel,
MEDER electronic group
<http://www.meder.com>

REED SWITCHES

REED SENSORS

REED RELAYS



MEDER Relays for RF applications

- DRF Series - DC to 12 GHz

DRF Insertion Loss

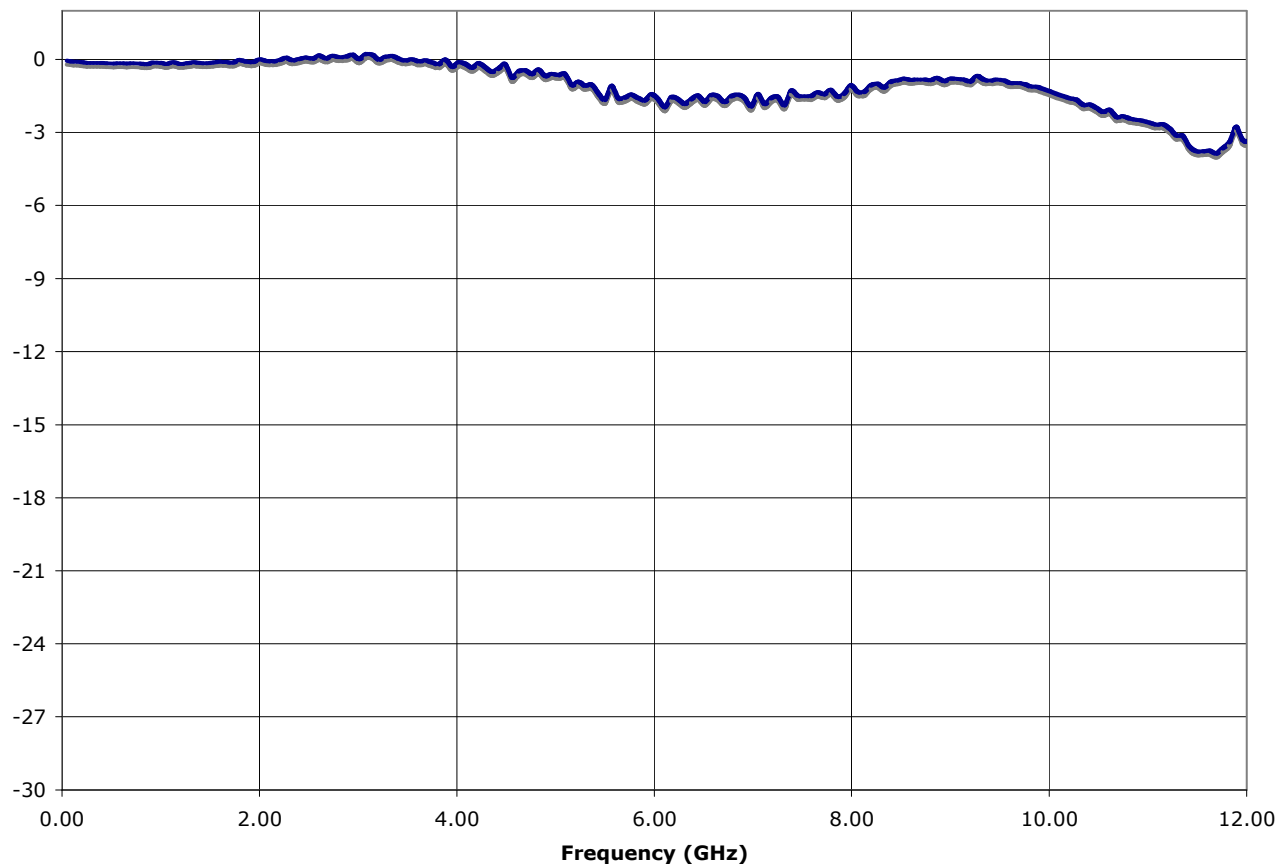

Copyright: John Beigel,
MEDER electronic group
<http://www.meder.com>

REED SWITCHES

REED SENSORS

REED RELAYS



MEDER Relays for RF applications

- SRF Series - DC to 16 GHz

SRF Insertion Loss

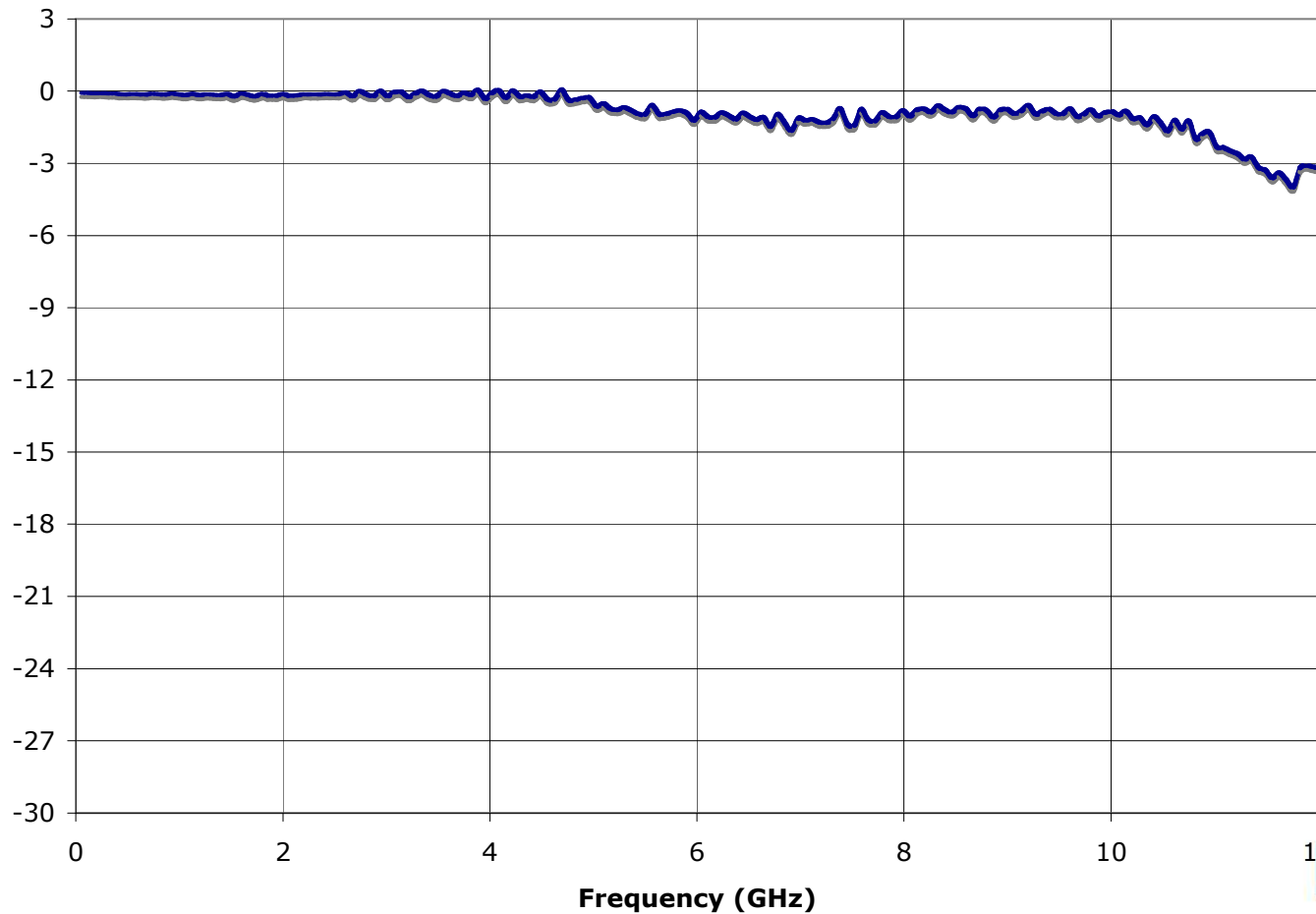

REED SWITCHES

REED SENSORS

REED RELAYS



MEDER Relays for RF applications

- RM 6 pole - DC to 3.5 GHz
- RM 4 pole - DC to 5.5 GHz
 - 4 inputs and 4 outputs
 - 4 inputs and 2 outputs

RM05-4AS-4/4 Insertion Loss

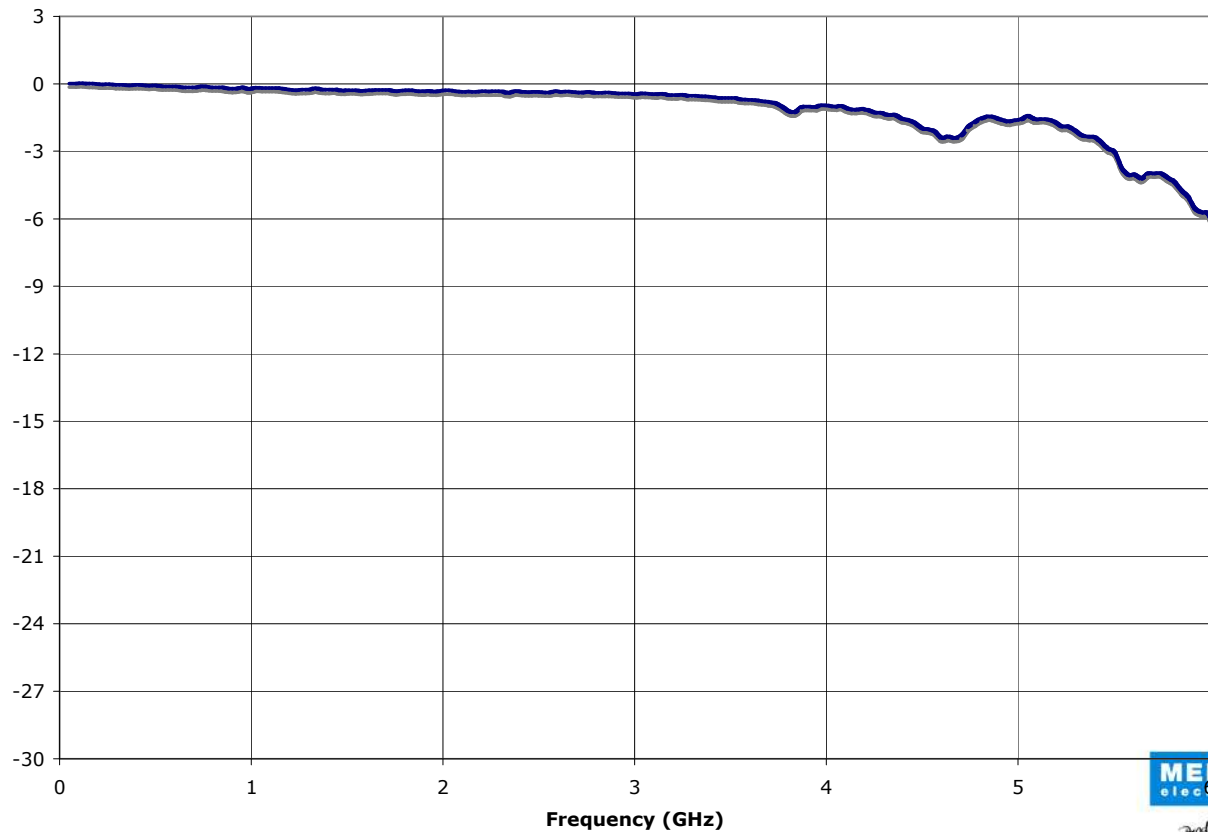

REED SWITCHES

REED SENSORS

REED RELAYS



Reed Switch Basics

- **End of part II**

Form B and Latching Reed Relays and Sensors:

- What are the key features of Form B and latching Relays and Sensors?
- Why is the magnet so important?
- Why is the coil so important?
- The hysteresis of the reed switch – the best way to understand Form B and latching action