

REED SWITCHES

REED SENSORS

REED RELAYS

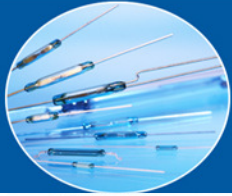

# MEDER electronic group

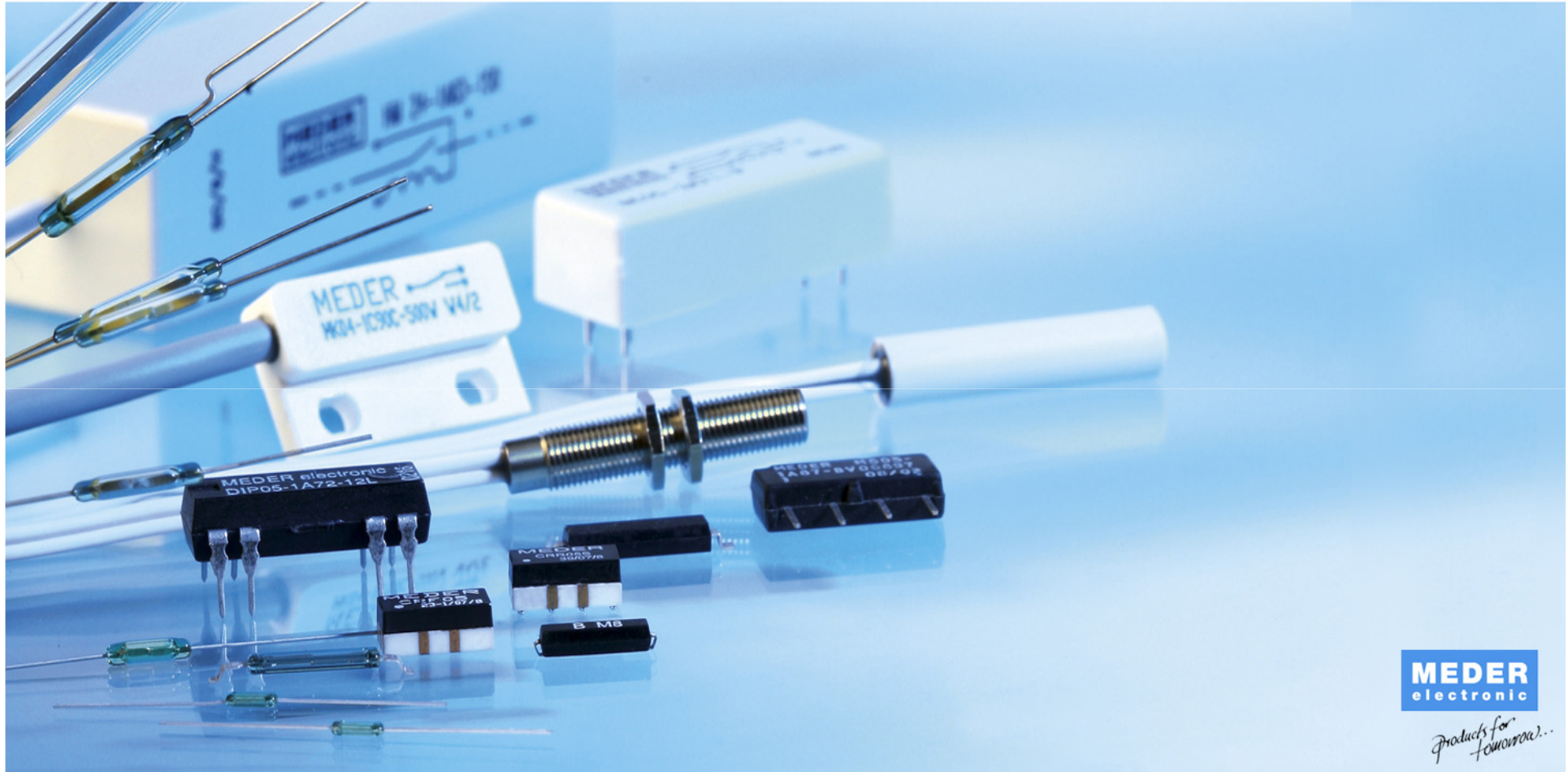

**MEDER**  
electronic

*Products for tomorrow...*

## Reed Switch Basics part III

Copy right: John Beigel,  
MEDER electronic group  
<http://www.meder.com>

04/03/2010

REED SWITCHES

REED SENSORS

REED RELAYS

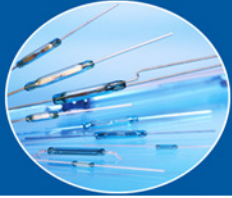

## Table of contents

- Dynamic Contact Resistance
- The Reed Switch as Reed Relay
- The Reed Switch as Reed Sensor

REED SWITCHES

REED SENSORS

REED RELAYS

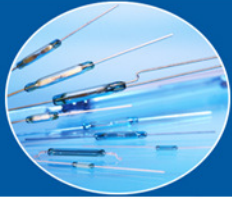

## What causes DCR disruptions?

- Over-stressed reed switch
- A small crack on the reed switch seal
- A broken reed switch
- Plating or sputtering peeling or flaking off the contact area
- Improper air mixture (moisture) inside the glass capsule
- Particles on the contacts

REED SWITCHES

REED SENSORS

REED RELAYS

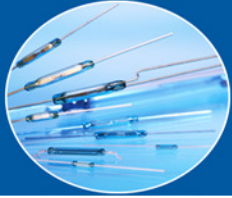

## Why test for DCR?

- DCR testing is a great way to qualify a new sensor or relay to make sure that all tools involved are not adversely affecting the fragile reed switch.
- This is particularly true in any operation involving bending or forming the reed, along with any over-molding of the reed.
- DCR testing will eliminate early failures and improve long term reliability in the customer's equipment and/or technical systems

REED SWITCHES

REED SENSORS

REED RELAYS

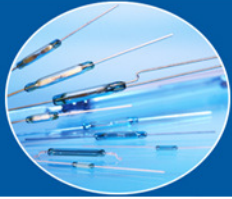

## DCR Parameters

- Reed switch size and the subsequent inductance of its coil can have a major influence in the dynamic switching characteristics.
- When the reed contacts come together, they do so with a certain momentum. That momentum makes the reeds vibrate in a simple critically damped harmonic motion.
- Critically damped harmonic motion is an important concept in our DCR testing.

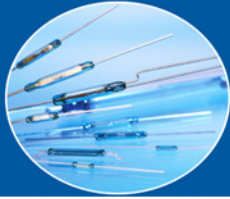

## DCR Parameters

- Larger reed switches have more inertia and the reed blades are stiffer. This in effect will create three things:
  1. The need for a magnetically stronger more inductive coil is required.
  2. It will increase the initial reed closure time.
  3. It will increase the effects of the critically damped harmonic motion.
- Conversely, smaller reed switches have less inertia and are not as stiff. Therefore, they will behave in an opposite manner compared to larger switches.
- Taking the size of the switch into consideration, therefore, is an important step in determining the parameters of the DCR testing.

REED SWITCHES

REED SENSORS

REED RELAYS

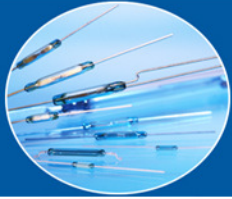

## DCR Parameters

- When the reeds undergo the critically damped harmonic motion they are moving microscopically inside the glass capsule.
- This movement is occurring in the magnetic field generated by the coil.
- When a metal is in motion in a magnetic field a current will be induced in the metal.
- This current is a critical part of the measurement of our Dynamic Contact Resistance .

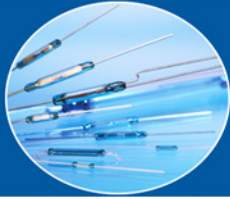

## DCR Parameters

- The overdrive of the coil is also a critical parameter in making the DCR measurement. Simply defined: it is the voltage (or current) above the actual pull-in (or closure) point where the DCR measurement is made.
- If the reeds close with 3.0 volts applied, adding an increased voltage above 3.0 Volts and testing at that point would represent the overdrive level.
- A reasonable overdrive number is 40%. Here for 3.0 Volts this represents a voltage increase of 1.2 volts or a test level of 4.2 volts applied to the coil.

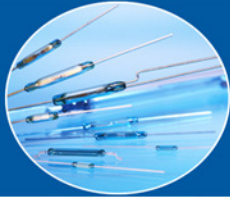

## DCR measured at Max Pull-in

- Max pull-in as the overdrive level is another approach.
- Here if the max Pull-in spec is 3.75 volts that is where the DCR measurement is taken.
- In this case, however, if some of the population are pulling-in at or near 3.2 volt this will represent only an overdrive of less than 15%.
- Again, this may represent an unfair testing approach and one may reject perfectly good reed relays (unfair in this case means throwing away perfectly good products).

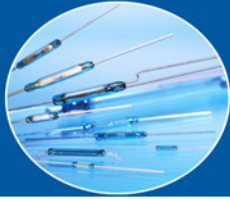

## DCR measured at Nominal Voltage

- Using the DCR measured at 5 volts also easy to set up by the test engineer may disguise potential problems with too much overdrive.
- It is not uncommon to have a lot of relays made that typically have a distribution of Pull-in over an expansive range.
- For a 5 volt relay it would not be uncommon to have a Pull-in of 2.0 volts. In this case, testing the DCR at 5 volts would represent 150% overdrive.
- 150% overdrive may cover up potential reed switch problems.
- Testing the DCR at 2.8 volts (40% overdrive) would be a better test

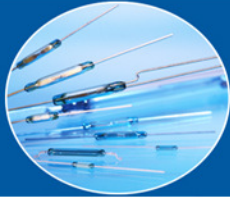

## When to Measure DCR

- Larger reed switches take longer to close as already described.
- Because of this, starting the DCR too early will mean throwing away perfectly good product
- Starting the DCR later with a smaller reed may create the opposite situation allowing too much time for settling
- 1.5 ms usually is an appropriate amount of time after the coil has been energized to perform the DCR measurement

REED SWITCHES

REED SENSORS

REED RELAYS

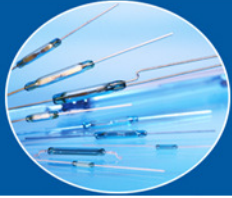

# Dynamic Contact Resistance

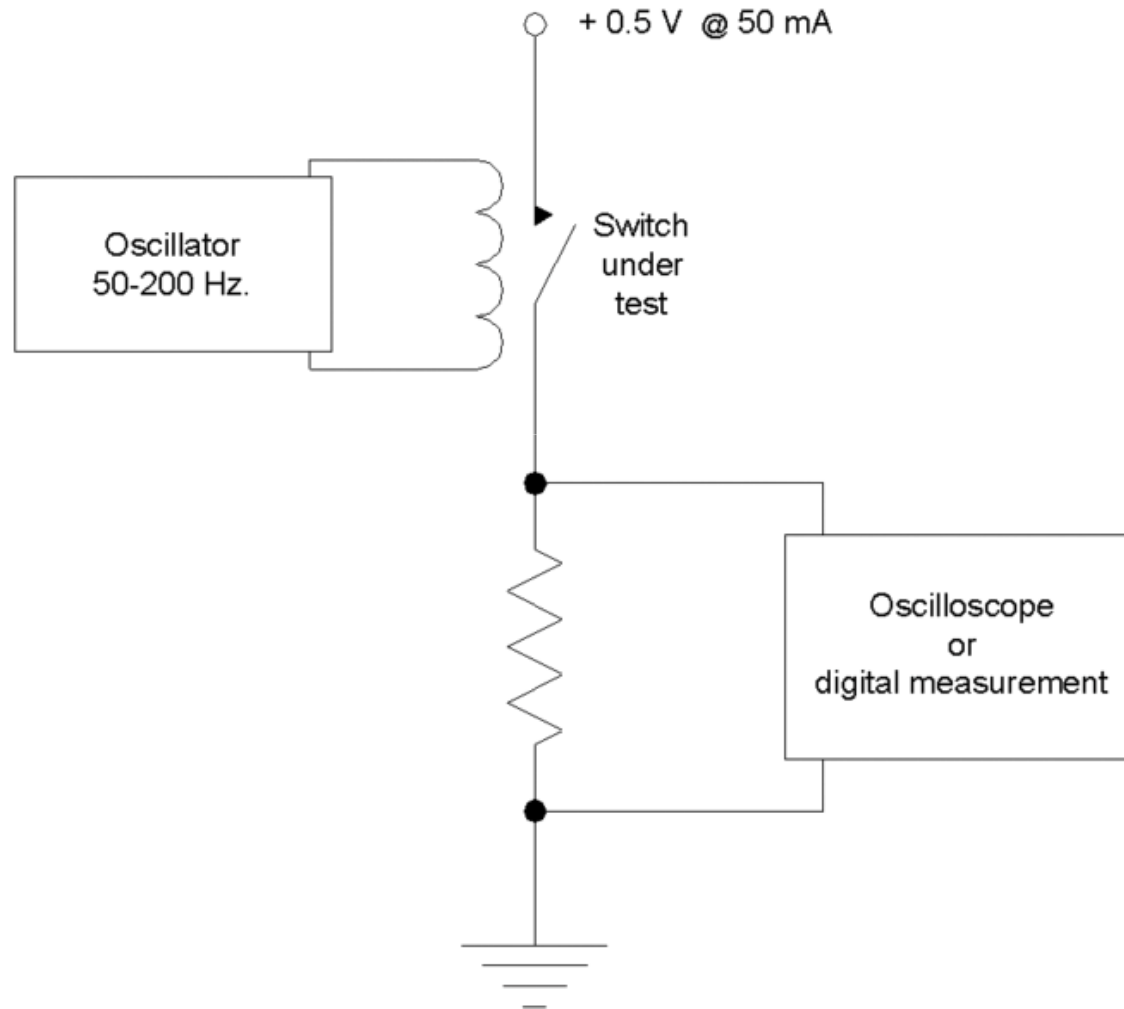

REED SWITCHES

REED SENSORS

REED RELAYS

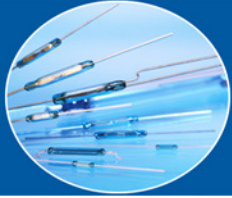

## The Reed Switch as Reed Relay

Placing a coil around the Reed Switch and passing a current thru the coil produces a magnetic field equivalent to a permanent magnet.

Placing a coaxial shield around the switch allows signals to be switched up to 20 GHz.

Because the Reed Switch has no wearing parts the contacts can switch low level signals well into the billions of operations.

The Reed Relay is used extensively throughout the test and measurement field.

Reed Relays are used in test systems, matrices, RF, modems, alarms, ideal for high cycle count, ideal for high voltage applications, ideal for low current and low voltage switching, etc.

REED SWITCHES

REED SENSORS

REED RELAYS

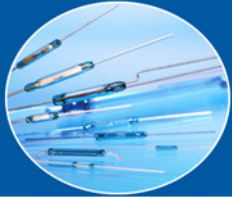

## The Reed Switch as Reed Sensor

As a Sensor the Reed Switch may sense all kinds of movement.

To do this a permanent magnet is used in conjunction with the Reed Switch.

The Reed Switch in the open state draws zero current.

The magnet's field can be effective even when separated by air, plastics, and metals.

This feature opens up a plethora of applications, where the sensing environment does not allow the movement of the magnet and switch to physically come together.

Usually the magnet and Reed Switch are divided or separated by physical housings or other obstacles.

Reed sensors are used for sensing movement, counting, detecting fluid levels, measuring fluid levels, switching in harsh environments, implantables, etc.

REED SWITCHES

REED SENSORS

REED RELAYS

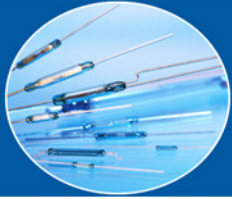

# Reed Switch Basics

- **End of part III**

Content of part IV:

- How a Reed Switch Sensing application works
- How a Reed Switch is used with a Permanent Magnet